

Mesoscale Data Assimilation and Prediction with Commercial Aircraft (TAMDAR) Observations

Yubao Liu^{*1}, Mark Anderson², Scott Swerdlin¹, Ming Ge¹, Laurie Carson¹, Wei Yu¹ and Tom Warner¹

¹ National Center For Atmospheric Research, Boulder, Colorado

² AirDat LLC, Evergreen, Colorado

1. INTRODUCTION

Mesoscale (10 - 2000 km) meteorological data assimilation and prediction are challenging due to the sparseness of observations, especially in the upper-air atmosphere. In the past 15 years, a number of instruments, e.g. wind profilers, commercial aircraft reports, satellite measurements, and others, have been developed to enhance the upper-air observations. Despite these advances, the present systems are still not sufficient for mesoscale data assimilation and prediction. In this paper, a new source of sensor data, called TAMDAR (Tropospheric Airborne Meteorological Data Reporting), is described. The impact of TAMDAR data on mesoscale weather analysis and short-term forecast are explored using the NCAR/ATEC (National Center for Atmospheric Research and Army Test and Evaluation Command) real-time multiscale, rapid-cycling, four-dimensional data assimilation and forecast (RTFDDA) system during the Great Lakes Field Experiments (GLFE) when the first TAMDAR fleet became operational.

2. TAMDAR DATA AND GLFE

TAMDAR sensors, recently developed by AirDat LLC, which is sponsored by NASA, are specially designed to instrument smaller commercial aircrafts that fly in the lower troposphere over the CONUS and other parts of the world. These sensors provide a full suite of meteorological measurements, including temperature, winds, humidity, icing, turbulence, et al., with very high time/space density. The measurement precisions of the meteorological variables are comparable to those of standard radiosondes, with 0.5 C for temperature, 5% for relative humidity, 4 knots for wind speeds and 5

degrees for wind directions. More details about the TAMDAR and calibration results can be found in Daniels et al. (2005). Starting in late 2004, AirDat worked with Mesaba Airlines to equip and operate Mesaba Airlines' fleet of turboprop regional aircrafts with TAMDAR sensors. By mid-January 2005, with 63 Saab 340s equipped with TAMDAR, a six-month Great Lakes Fleet Experiment (GLFE) was launched by NASA, NOAA, FAA and AirDat, to demonstrate and evaluate the value of this pilot TAMDAR system (Moninger et al., 2005). The operational flights of the equipped Mesaba Saab 340 aircrafts provide about 800 soundings a day and ~20,000 meteorological reports. The GLFE experiment initially spun six months, from January 15 to July

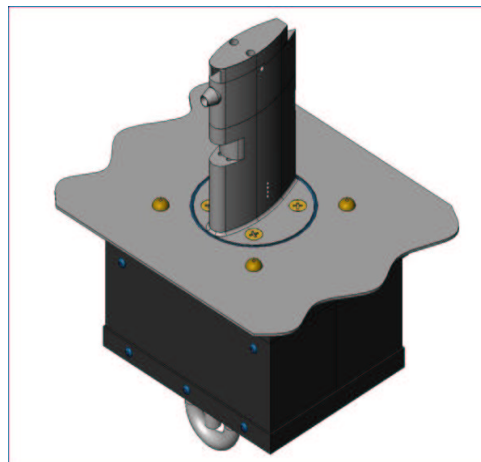

Fig. 1 Picture of the TAMDAR sensor developed by AirDat LLC

15, 2005. It has been extended through the

Corresponding author address: Yubao Liu, NCAR/RAP, P.O. Box 3000, Boulder, CO 80307-3000; email: yliu@ucar.edu. NCAR is sponsored by NSF.

summer and fall of 2005 in order to study the TAMDAR data impact on mesoscale NWP in summer convective situation. During the whole GLFE period, the TAMDAR data were available for public access.

3. THE NCAR/ATEC RTFDAA SYSTEMS

As a part of the GLFE program, the NCAR/ATEC RTFDAA system was used to evaluate and explore the value of the TAMDAR data. The RTFDAA system was originally built around the Penn State/NCAR Mesoscale Model version 5 (MM5). By effectively incorporating detailed terrain, coastline masks, and land-use information, and using synoptic-scale model analyses from the NWS and real-time mesoscale observations, the RTFDAA system has proven capable of forecasting many realistic local circulations (Liu et al. 2002). Besides running operationally at five US Army Test ranges a few other sites under Homeland Security, as of Sep. 2005, the RTFDAA systems have also been implemented at 20+ other sites/regions globally, supporting various Department of Defense missions and other applications.

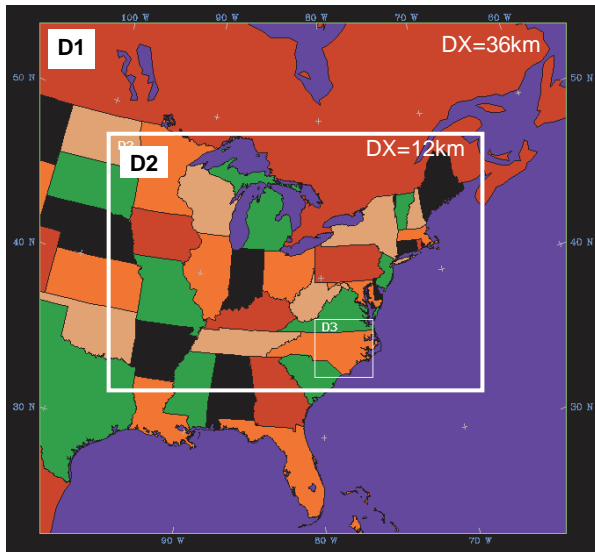

Fig. 2. GLFE RTFDAA domain configuration.

The 4-D continuous data assimilation scheme of the RTFDAA system is capable of weighting each observation according to its observation time and location, and thus it is able to elegantly assimilate the aircraft data measured along flight legs, which can be very irregular in

time and space. The RTFDAA system incorporates various observations including the standard WMO/GTS radiosondes, METER, ship and buoy observations, wind profiler, AMDAR/ACARS, satellite derived winds, various mesonets, radar VAD winds and many other measurements. During GLFE, two paralleled RTFDAA systems with the same model configuration, except one makes use of extra TAMDAR data and the other does not, are operated to study the impact of TAMDAR data. The models are configured with two nested domains with 36 and 12 km grid increments respectively. The fine mesh (12-km grid mesh) covers the Great Plain and eastern States where Mesaba Airlines fly and/or where TAMDAR data may immediately affects (Fig.1). Both systems are cycled at a time interval of 3 hours and in each cycle, 4 hour final analyses and 12 hour forecasts are produced for $t - 4$ h to t and t to $t + 12$ h respectively. The NCEP ETA-AWIP 212 forecasts are used to derive lateral boundary conditions during the RTFDAA system cycling, and initial conditions at cold-starts, which occur once a week.

4. IMPACT ON PRECIPITATION PREDICTION

The model verifications are carried out by comparing the model output with point observations of temperature, moisture and winds from radiosondes and surface stations, and/or by comparing the model 2D/3D fields with radar observations and NCEP Stage IV precipitation analyses. The verification statistics of conventional Root Mean Squared Errors and Bias Errors are presented in the next section. In this section, subjective verification by comparing the model precipitation with WSR-88D CONUS mosaic reflectivity fields and NCEP Stage IV hourly and 3-hourly accumulated precipitation analyses were conducted.

This comparison is of importance because precipitation structure and distribution mostly characterize the timing and intensity of weather systems. More importantly, because the cloud and precipitation are not assimilate to the RTFDAA system, the differences of precipitation fields of the RTFDAA analyses, to a large extent, reflect

the successfulness of the data assimilation scheme and the impact of data being assimilated.

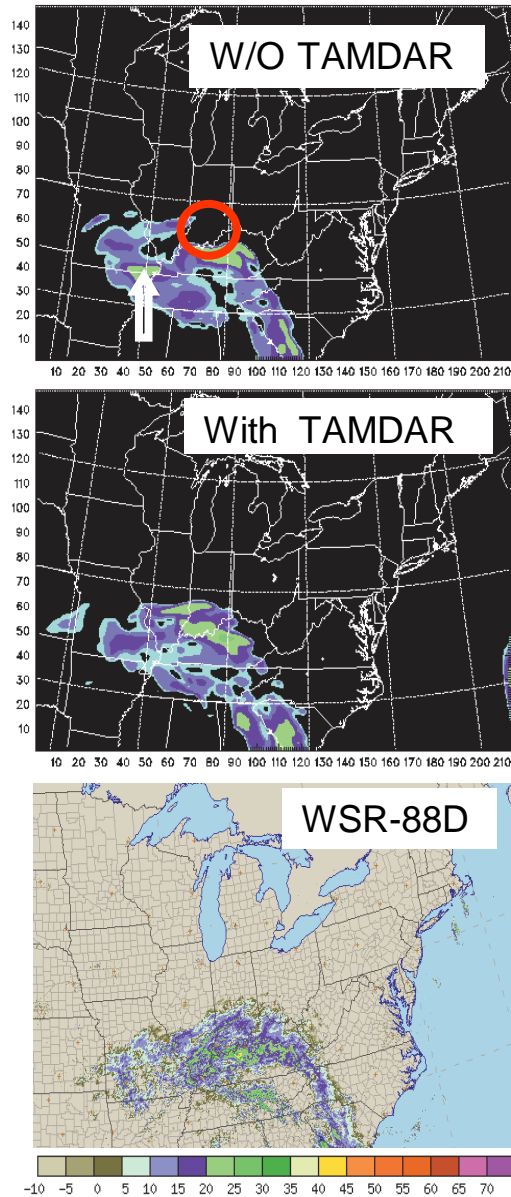

Fig. 3 Comparison of RTFDFA reflectivity with WSR-88D observations, valid at 18Z 02 Feb 2005.

Monitoring day by day forecasts of the RTFDFA outputs from the GLFE operation with and without TAMDAR data, we found that both model systems were able to forecast the overall precipitation system reasonably well. During the GLFE winter season, none of the system missed one major precipitation system. On the other hand, the addition of TAMDAR data did lead to a lot of adjustments of the detailed, meso-beta and

gamma scale structures of the rain bands and cores, and there are a great number of cases in which TAMDAR data improved these small scale features.

Fig. 3 shows an example of the RTFDFA precipitation analyses with and without use of TAMDAR data. Comparing with the WSR-88D observations, TAMDAR evidently improves the overall precipitation distribution of the snow bands. For example, RTFDFA runs without TAMDAR data missed the precipitation over the southern Indiana (see the red circle area) and it falsely generated a snow core to the eastern part of the boundary between Missouri and Arkansas (white arrow). In contrast, the RTFDFA with TAMDAR simulated more accurately the precipitation cores in the middle Kentucky and southern Illinois.

5. VERIFICATION STATISTICS

Statistical verification of the model analyses and forecasts are conducted using all hourly surface reports and radiosondes at 00Z and 12Z. For each observation, the model analyses and forecasts of different forecast lengths valid at the observation time, are interpolated to the observation point and time, forming a model-observation pair. Statistics are calculated based on these pairs according to different aspects of interests, including averages on different domains, or averages relative to GMT hours, or averages according to forecast lengths or average according to stations ...

5.1 Daily Evolution of Upper-air Errors

TAMDAR airplanes mostly fly below 600 hPa. Thus the 850 hPa and 700 hPa verification results indicate more direct impact of the TAMDAR data, whereas 500 hPa and above are indirectly influenced by the data, mostly through model dynamical adjustments.

Fig. 4 compare the daily mean RMSE errors of temperature, moisture and winds of the model 12 h forecasts with and without TAMDAR data at 850 hPa, averaged over Domain 2. TAMDAR data evidently improve the RTFDFA analyses (not shown), and a larger positive impact of TAMDAR data can be seen in the forecast periods

for all variables (T, Q, RH and winds). The 6 hour forecasts (not shown) are improved most, but the positive impact is well extended to the 12 hour forecasts (Fig.4). Although there are large day-by-day variations of the gains introduced by the TAMDAR data., generally, an overall positive impact of the data. can be identified.

The verification results at the 700 hPa level are very similar to those at the 850 hPa, (not shown). The relative improvements of the TAMDAR runs are larger. Since the TAMDAR aircrafts mostly fly in the layer between the ground surface and 600 hPa, the similarity between the verification results at 850 hPa and 700 hPa suggests consistent effect of TAMDAR on the model simulation in the observed layer.

Although the TAMDAR data are available in the lower troposphere, their impacts appear to extend to the upper troposphere. Comparison of the forecast errors between the model runs with and without TAMDAR data on 500 hPa level (not shown) indicates apparent benefit of TAMDAR data in the layer. The phases of daily-error evolution in the upper-levels are consistent with those seen in the lower levels. On those days when we have the larger impact of TAMDAR data in the observation (lower) levels, we also observe the larger positive impact on the upper-levels.

5.2 Jan. 29 to Feb. 5, 2005

The daily verification of the three-week model runs discussed above indicated that the TAMDAR data play an exceptional role during a 7 day period from Jan. 29 to Feb. 5, 2005. During this period, two episodes of precipitation systems swiped through the middle of US.

The vertical profiles of mean BIAS and RMSE errors of the model temperature, moisture, wind speed and vector wind differences, averaged over the Domain 2 for the selected period are shown in Fig. 5. It can be seen that the TAMDAR data not only reduce the already small bias errors of temperature and moisture fields (except for the near surface layer and in the tropopause), but also greatly reduce their RMSE errors. The RMSE errors of the temperature and moisture mixing

ratio of the TAMDAR runs are about 20 - 30 % smaller than those of no-TAMDAR runs throughout most troposphere. Wind speed bias in a deep layer below 300 hPa appear to be improved by the TAMDAR data and the vector wind differences (VWD), which combine the information of wind speed and direction errors, show dramatic improvements by the TAMDAR data. The VWD with TAMDAR runs is reduced by ~30 % in the troposphere, and a positive impact also exists in the lower tropopause.

Two points are of particular interest t. First, the TAMDAR data, although only available in the lower troposphere, lead to obvious improvements to the model analyses and forecasts in both lower troposphere and upper-troposphere. The RTFDDA data assimilation scheme imposes data impact on the model states in a dynamically consistent way, and the resultant improvements are integrated, spanning from the observation layers up to the upper observation-void layers.

Secondly, with TAMDAR data, the FDDA process appears to be able to enhance the analyses at the times when synoptic soundings are taken. This can be understood when one keeps it in mind that analyses are verified against the soundings that have been used in the analyses. The addition of the TAMDAR data causes slightly better match between the analyses and the soundings. This result suggests that the model backgrounds for the analyses are improved by the TAMDAR data, and the TAMDAR observations are consistent with the sounding data with proper observation accuracies.

rms_850_f1012

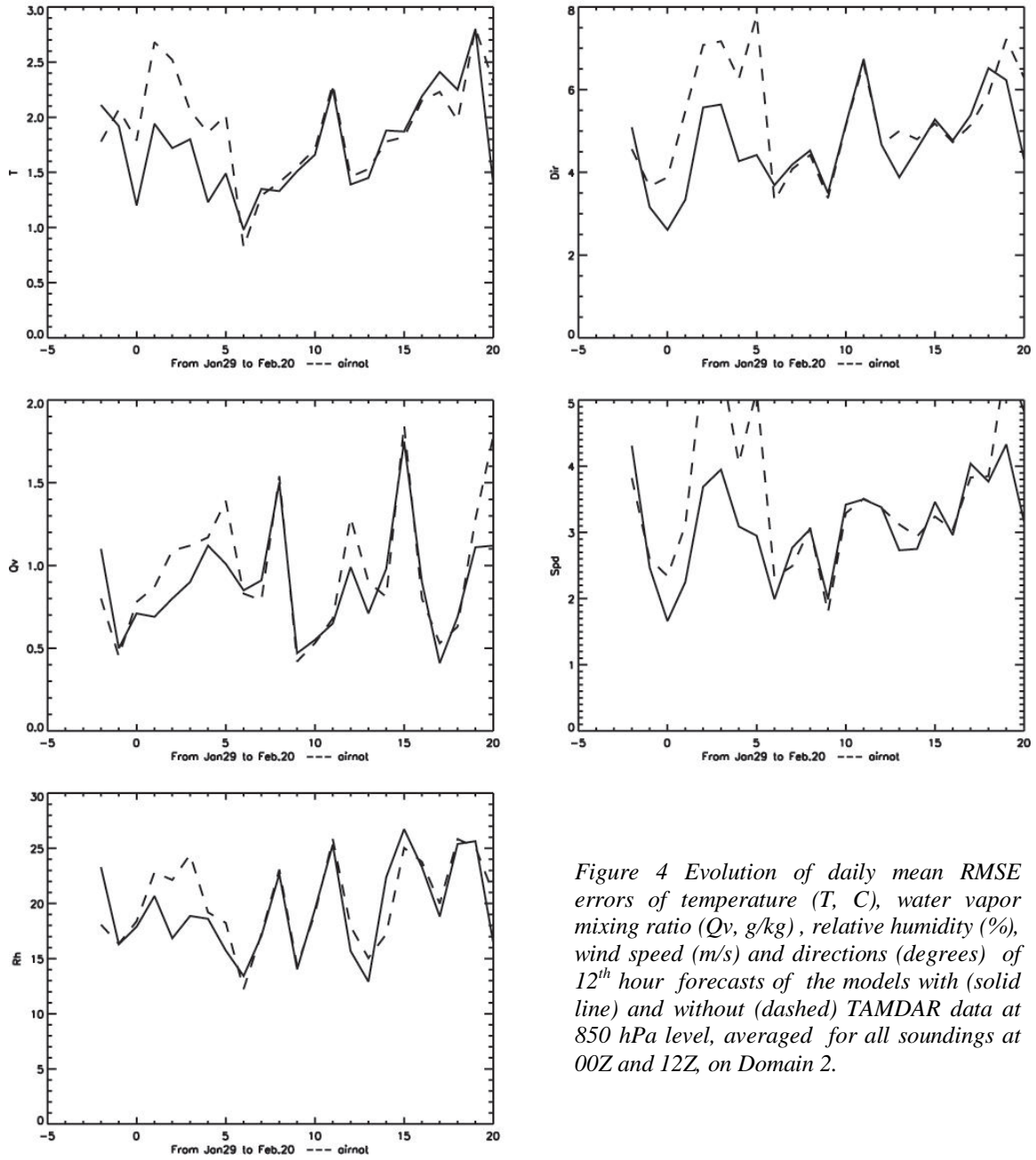

Figure 4 Evolution of daily mean RMSE errors of temperature (T, C), water vapor mixing ratio (Qv, g/kg), relative humidity (%), wind speed (m/s) and directions (degrees) of 12th hour forecasts of the models with (solid line) and without (dashed) TAMDAR data at 850 hPa level, averaged for all soundings at 00Z and 12Z, on Domain 2.

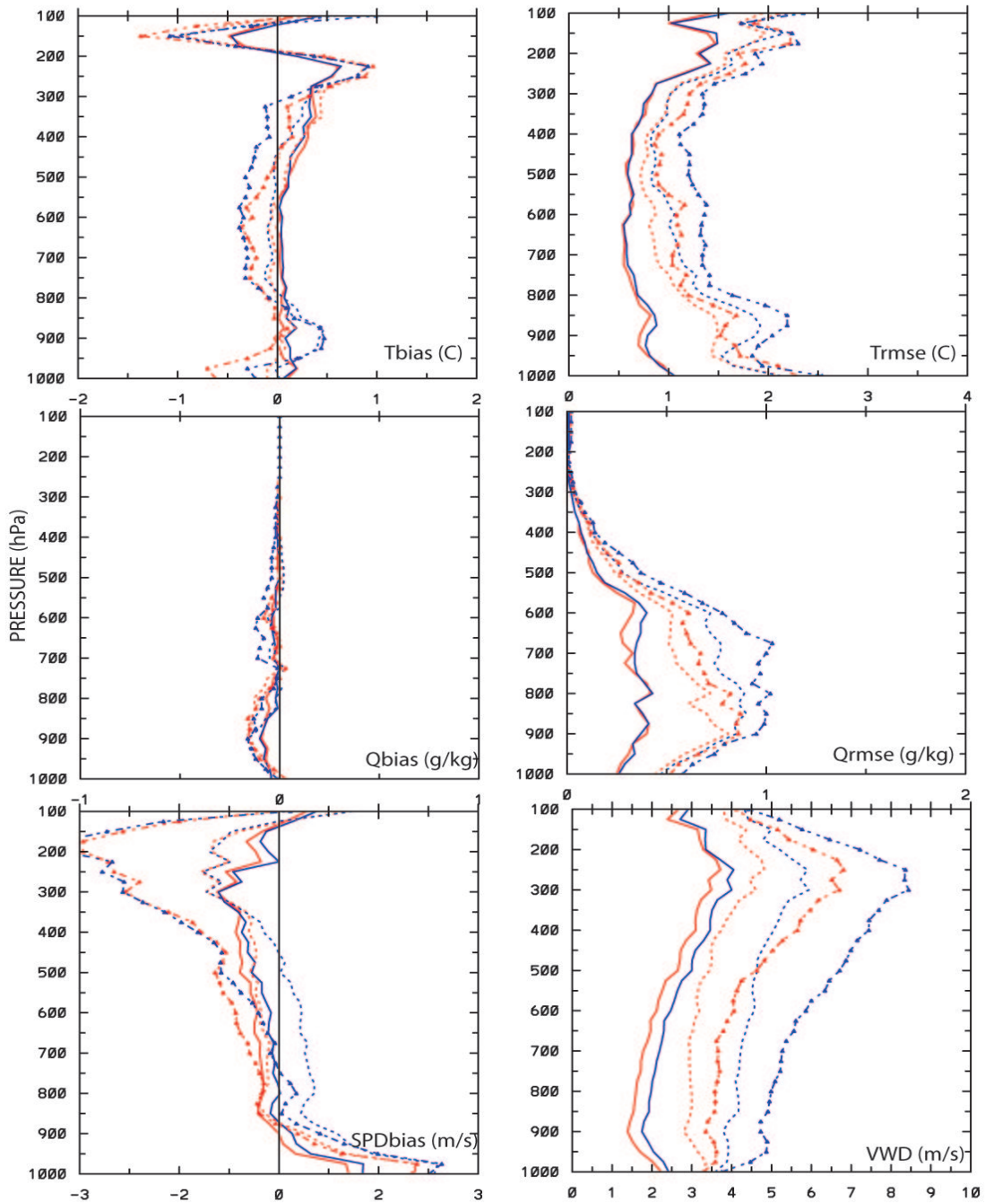

Fig. 5 Vertical profiles of mean BIAS (left panels) and RMSE (right panels) of the model temperature, moisture mixing ratio, wind speed and vector wind differences, averaged over the Domain 2 for the period between Jan 29 and Feb 5, 2005. The solid lines denote the analyses, dashed lines are the 6 hour forecasts and the dashed with solid triangles are for 12 hour forecasts. The results with TAMDAR data are shown in red and the ones without are shown in blue.

5.3 Surface Verification Statistics

Verification of model surface analyses and forecasts (figure omitted) shows that TAMDAR data slightly improve the surface winds of RTFDAA analyses and forecasts. Nevertheless, it seems to have little influence on the surface temperature and moisture analyses and short (0 – 6 hour) forecasts in terms of the diurnal and domain-scale spatial average. The impact of TAMDAR data on the 10 – 12 hour forecasts of surface temperature are not significant either. It is speculated that the surface temperature and moisture are dominated by the land-surface forcing which has a larger inertia to small changes of upper-air circulations. Indeed, when looking at the evolution of the hourly verification statistics through the 3 week period, both model runs exhibit large diurnal variation of errors, which is primarily due to the land surface forcing processes.

6. SUMMARY

Impacts of TAMDAR data on mesoscale meteorological data assimilation and short-term forecasts were evaluated by verifying the real-time RTFDAA products generated by identical twin-models: one uses all data and the other with the TAMDAR data withheld. Surface and upper-air daily average forecast errors of the model runs are computed. It is found that for the winter season, TAMDAR data generally generate positive impacts on the mesoscale analyses and forecasts, and in some cases, the data can improve the forecast of upper-air weather variables by 25 – 35%. The domain average of surface forecast errors seems to be insensitive to the TAMDAR data, due partly to the generally stable winter weather regime, partly to the strong controlling roles of the underlying land surface and soil properties, and partly to outliers of stations. Visual comparison of the model precipitation analyses and forecasts with radar observations indicated that, in some cases, the TAMDAR data are able to improve meso- and small structures and timing of the model precipitation systems.

Case studies display apparent advantages of the RTFDAA model in very short-term precipitation forecasts over the RUC and NAM operational products on the precipitation structure

and organization. By assimilating only thermodynamic, moisture and winds, the RTFDAA model is able to produce cloud and precipitation “analyses” that are closely agreeable with the observations for the winter season. The RTFDAA model resolution (12 km grid) used here is the same as those of NAM, and also close to those of RUC (13 km). The “spin-up” analysis/initialization through continuous data assimilation in the RTFDAA allows the model to provide high quality nowcasting outputs of precipitation (and other fields too), whereas the 3D nature of the RUC and NAM model analyses/initialization suffers from the “spin-up” processes, although the models also generate rain in a few forecast hours. Further comparison with more weather cases and longer forecast lengths will be carried out. A WRF-based RTFDAA, which is under development at NCAR/RAL will be used to replace the current MM5-based RTFDAA. This will provide a chance for more interesting inter-model comparison in the future since the same WRF framework will be also used to upgrade both RUC and NAM for NCEP operation.

Finally, the results shown here are mostly based on objective verifications of a short-period of model operations using the point-statistical approach which is known to penalize the benefit of high-resolution mesoscale models. Further analyses of the detailed processes of the model response to the TAMDAR data, variation of TAMDAR data impact in associated with weather regimes, especially during the summer unstable convective weather scenarios, and use of more advanced verification approaches will be needed and beneficial. Furthermore, work is in progress to study the TAMDAR data impact with sensitivity experiments on different weather regimes. The data assimilation scheme for assimilating TAMDAR data will be refined to maximize the value of this data source. Other data-denial experiments will be conducted to compare the effect of TAMDAR data with other existing measurement platforms. Finally, the current large D2 at 12 km grid size may be too coarse to take the best use of the TAMDAR data. It will be interesting to run experiments with higher resolution models.

7. REFERENCES

- Daniels, T.S., W. R. Moninger and R. D. Mamrosh, 2006: Tropospheric Airborne Meteorological Data Reporting (TAMDAR) Review. 10th IOAS-AOLS, AMS, Atlanta, 29 Jan – 2 Feb. 2006.
- Liu, Y., and co-authors, 2002: Performance and enhancement of the NCAR/A TEC mesoscale FDDA and forecast system. *15th Conf. on Numerical Weather Prediction*, 12-16 August 2002, San Antonio, Texas, 399-402..
- Moninger, W. R., T. S. Daniels and R. D. Mamrosh, 2006: Automatic Weather Reports from Aircraft: TAMDAR and the U.S. AMDAR fleet. *12th Conf. on Aviation Range and Aerospace Meteorology*. AMS, Atlanta, 29 Jan – 2 Feb. 2006.